

NIKKEN Combinazione di attrezzature per centri di lavoro

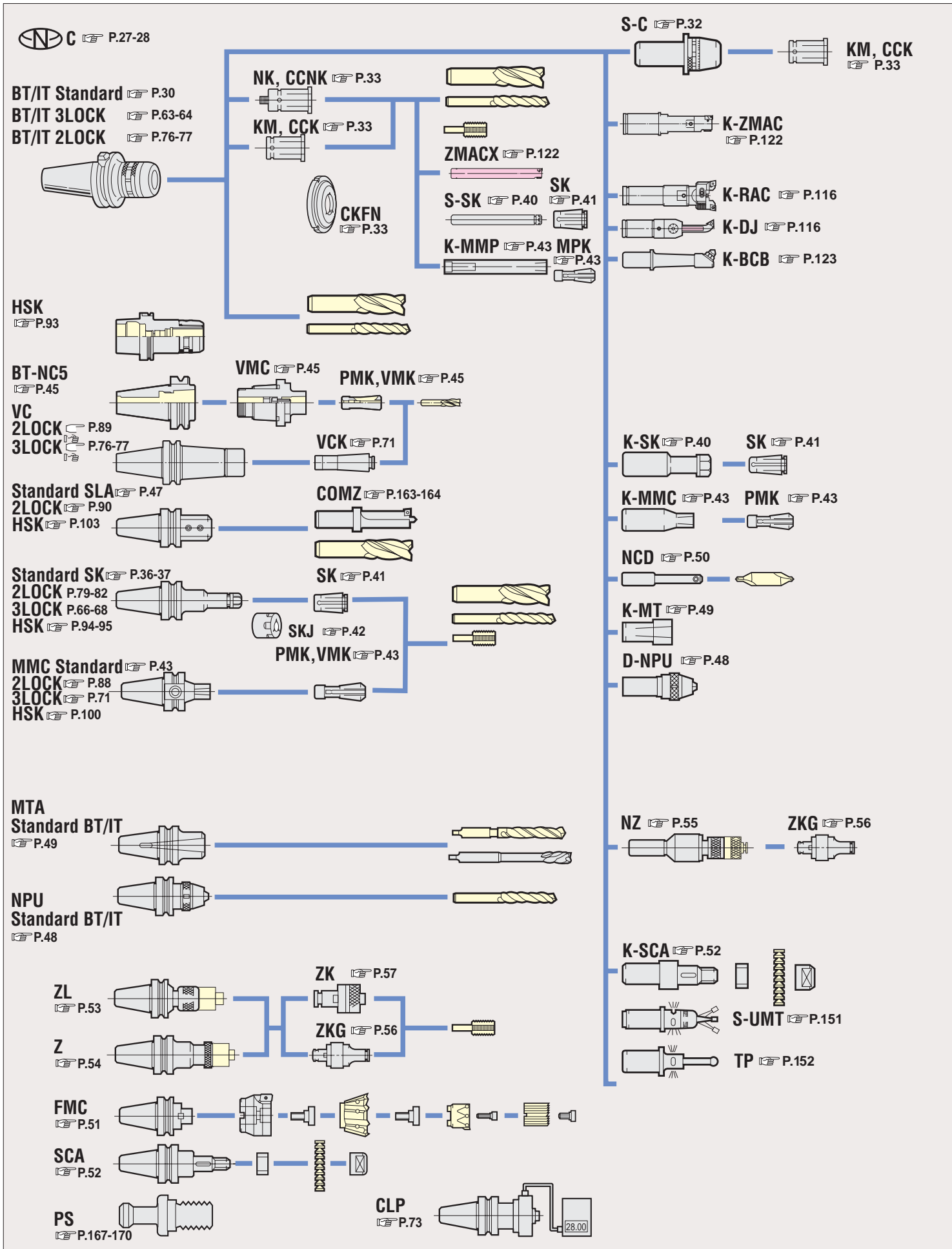

La nuova generazione di attacchi per centri di lavoro

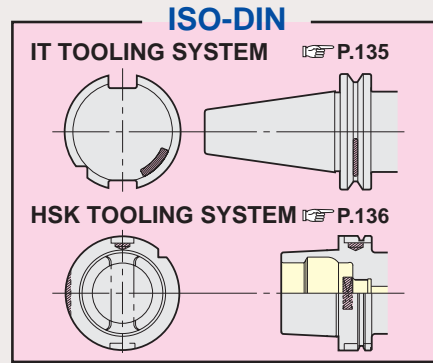
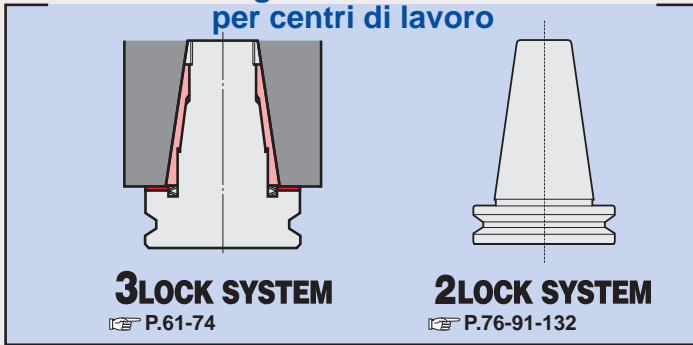

DJ P.120 **J** P.121

ZMAC P.118

RAC P.119

MCC P.124 **RCC** P.

NX P.139

MO P.135-136

OZL P.137

AH P.141-144

UMT **UMS** P.151

TP P.152

UDS P.153 **HP** P.150

E238 P.149

ATTACCHI BASE Q P.115-116

SP P.117

MCCB P.124

ALESATORI P.124-132

COMBAT Z DRILL P.163-164

DJ P.120-121

ZMAC P.118

BCB P.119

RAC P.119

INSERTI P.130-131

Mandri Major Dream per calettamento a caldo P.132-133

Mandri con passaggio di refrigerante dalla flangia P.32-39

CLE P.73

CZF, SZF ZERO FIT P.106-110

CNC P.179-182